



**neptronic®**

# BACnet MS/TP Overview Manual



This manual includes:

- Network Wiring Guidelines
- BACnet Address (Mac & Device Instance) - Setting Information
- Baud Rate - Setting Information
- Trouble Shooting Tips



# Contents

Introduction .....	1
About BACnet .....	1
About MS/TP Protocol .....	2
EIA-485 .....	2
Wiring .....	2
Network Cable Type .....	4
Maximum Number of Devices .....	4
Maximum Network Length .....	4
Shield Wiring Recommendations .....	4
End of Line (EOL) Termination .....	5
Repeater Usage .....	6
Addressing .....	8
Baud Rate .....	8
Addressing .....	8
Device Instances .....	8
MAC Addresses .....	8
Master - Slave .....	8
Max Master .....	8
Optimize MAC Address & Max Master .....	8
MAC Address Settings via DIP Switches .....	9
Troubleshooting Tips .....	9



# Introduction

---

The BACnet MS/TP Overview Manual details the concepts of BACnet and MS/TP.

## About BACnet

BACnet is a data communications protocol for Building Automation and Control Networks. It is an approved and standard protocol by American Society of Heating, Refrigerating and Air Conditioning Engineers (ASHRAE), American National Standards Institute (ANSI), and International Organization for Standardization (ISO). The BACnet protocol supports communication and control of applications such as heating, ventilation, air-conditioning, lighting, access, and fire detection systems and their associated equipment.

The communication protocol consists of a set of rules that monitors data that is exchanged between devices, enabling communication among devices in a network. The exchange of information can include values of temperature, humidity, alarm status and so on.

To communicate between devices, the BACnet protocol uses **services** and **objects**.

- **Service.** A service is a means or interface between two devices to access and process information, request to perform an action, or inform the devices that some event has taken place. These are used for discovering devices and objects, and for sharing data. Refer to the appropriate BACnet guide of the device used to verify which services are supported. The following are some of the important services:
  - Who-Is (Device and Object Discovery)
  - I-Am (Device and Object Discovery)
  - Who-Has (Device and Object Discovery)
  - I-Have (Device and Object Discovery)
  - Read-Property (Data Sharing)
  - Read-Property Multiple (Data Sharing)
  - Write-Property (Data Sharing)
  - Write-Property Multiple (Data Sharing)
  - Subscribe COV
  - Subscribe COV Property
  - Confirmed COV Notification
  - Unconfirmed COV Notification
- **Object.** An Object along with its set of properties describes the current status of a device to the other devices on the network. Objects enable reading, writing, and performing the desired functions of a device. Refer to the appropriate BACnet guide of the device used to verify which object types are supported. The following are some of the objects:
  - Analog Input
  - Analog Output
  - Analog Value
  - Binary Input
  - Binary Output
  - Binary Value
  - Device
  - File (available on recent specific models only)
  - Multi-State Value
  - Program (available on recent specific models only)
  - Schedule (available on recent specific models only)

## About MS/TP Protocol

The BACnet Master Slave Token Passing (MS/TP) protocol is used to relay and exchange information between building devices. The MS/TP is based on BACnet standard protocol SSPC-135, Clause 9. The BACnet MS/TP is a peer-to-peer, multiple master protocol based on token passing. A token is information packets in the form of a pulse signal that is passed between devices on a network.

### EIA-485

The BACnet MS/TP protocol uses EIA-485 (RS-485) as the physical layer standard for data transmission. Neptronic Controllers also use the BACnet MS/TP protocol over an RS-485 standard for communicating with third party routers, gateways, or master controllers.

## Wiring

The communication wiring must be installed in a proper daisy chain format. Daisy chain configuration means that there is only one main cable and every network device is connected in parallel directly along its path. It is important to keep the same color for all the A+ wiring and a different color for all the B- wiring. Do not use a free topology and/or star configuration on the network. This will cause reflection issues.

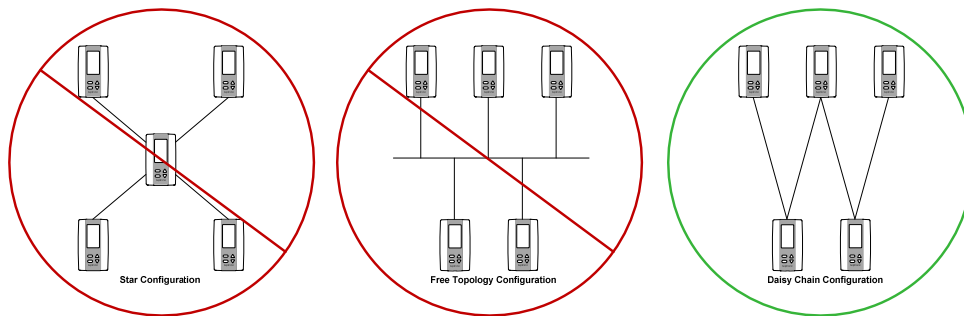
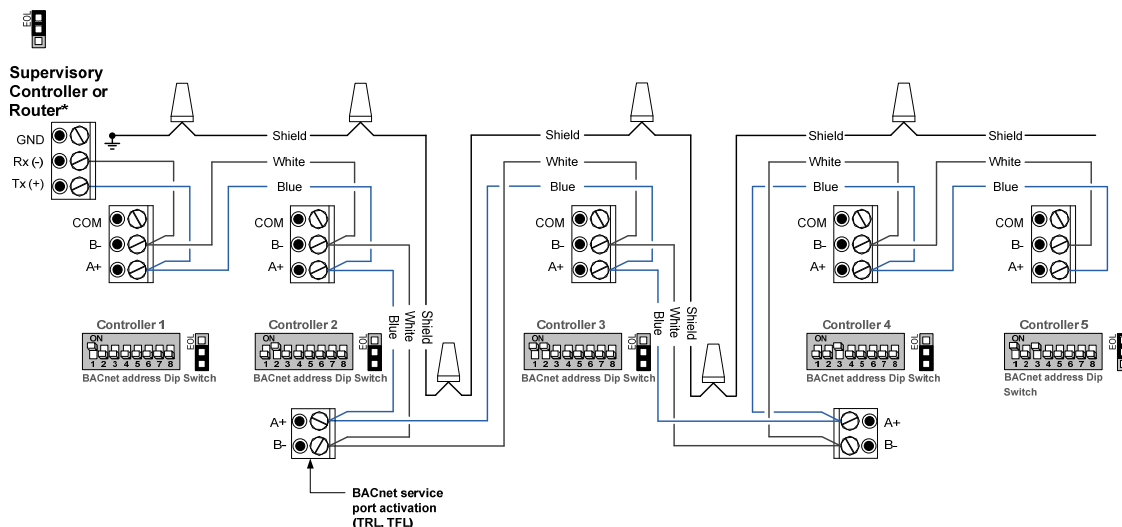

Illustration 1 - MS/TP Network Configuration Example

Here is an illustration of the correct MS/TP network wiring;



\*Indicates non Neptronic devices or equipment.

Illustration 2 - MS/TP Network Correct Wiring



Here are a few tips for the network wiring:

- Avoid unwinding the twists of cable when not necessary. Twisting the insulated conductors around each other reduces outward noise and improves immunity to external noise pickup.
- Avoid exposing too much bare wire so that adjacent wires do not short when connected to the controller.
- Twist the two A+ wires together before inserting them into the corresponding screw terminal of the controller.
- Avoid running network cables near DC signal switches, variable frequency drives and power lines (sources of electricity). These are the most common sources of induced noise.
- Secure the network cables to reduce vibration as much as possible.
- Do not use T-taps (pig tails) on the network. Controllers may drop out of the token pass or packets may be lost. See illustration below for examples of T-taps.

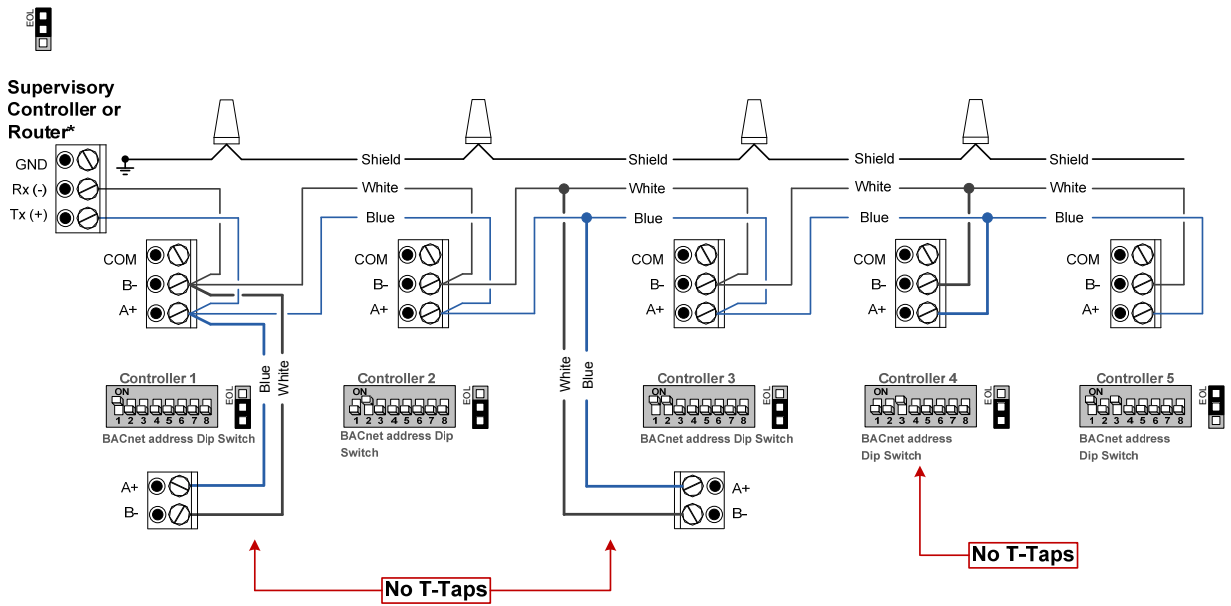

Illustration 3 - T-taps (pig tails)



You should avoid using the In and Out terminal screws for communication. If the terminal block is removed the daisy chain will be broken and you will lose all the devices located after.

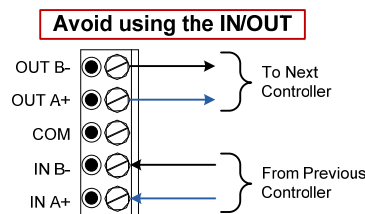

Illustration 4 - Communication In/Out

## Network Cable Type

Neptronic recommends using low capacitance, EIA RS-485, 22 or 24 AWG shielded twisted pair cables such as Belden 9841 or equivalent. You should always verify the Specification & Installation Instructions for the suggested cable type and size.

## Maximum Number of Devices

The Neptronic MS/TP network supports a maximum of 127 devices (with one or more repeaters) or 64 devices (without a repeater). We recommend using a maximum of 64 devices to reduce traffic and minimize network response latency. If more than 127 devices are required on the total network, then use extra BACnet MS/TP routers. When 64 devices are on a single MS/TP segment, we recommend using a baud rate of 38,400bps with a maximum network wire length of 4,000ft (1,200m). Note that each MS/TP supervisory controller and repeater counts as a device

## Maximum Network Length

BACnet MS/TP allows the total length of the twisted pair bus to be up to a maximum of 4,000 feet (1200 meters) using data rates from 9,600 to 100,000bps. This condition is only valid when proper installation and cables are used. The maximum baud rate supported by the Neptronic BACnet controllers is 76,800bps.

If a network requires more than 4,000 feet (1,200 meters) in length, then repeaters must be used to extend the trunk length.

## Shield Wiring Recommendations

Do not use the reference (COM) terminal on the controllers to wire the shields. Shields from each feed of the network connection to a controller should be wired together. Special attention must be taken to ensure that the shields are well protected (ends tapped or covered) to prevent any connection to ground that could influence the shield reference. This could create ground loops and change the reference level of the network. The shield in a daisy chain format is then grounded at one end only (usually on the supervisory controller or router side). Do not ground the shield at more than one location as you may induce ground loop noise.

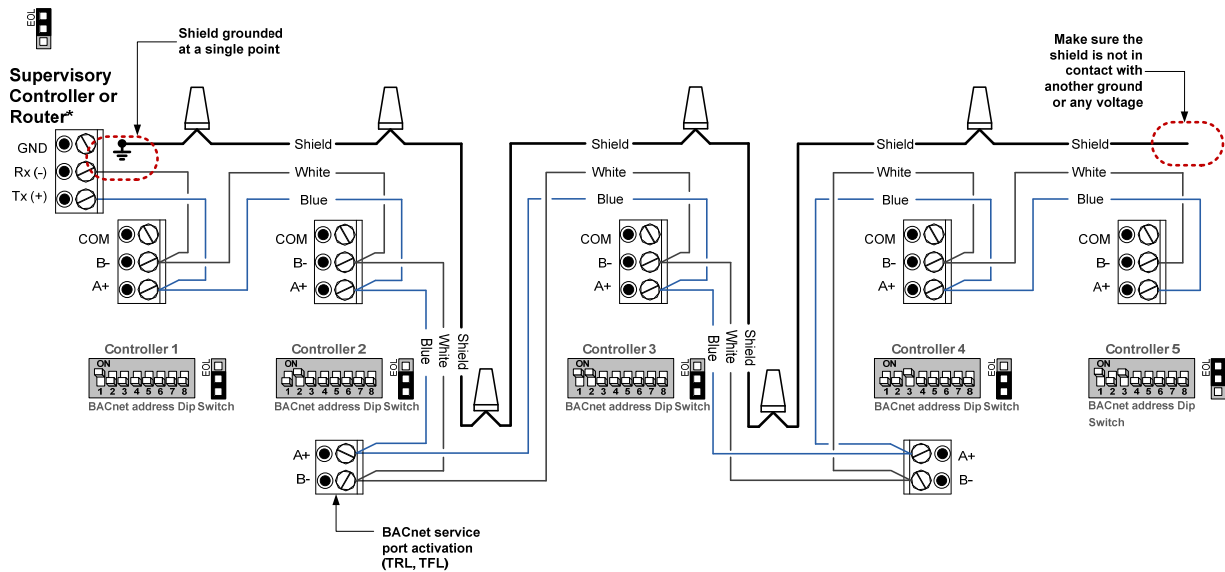
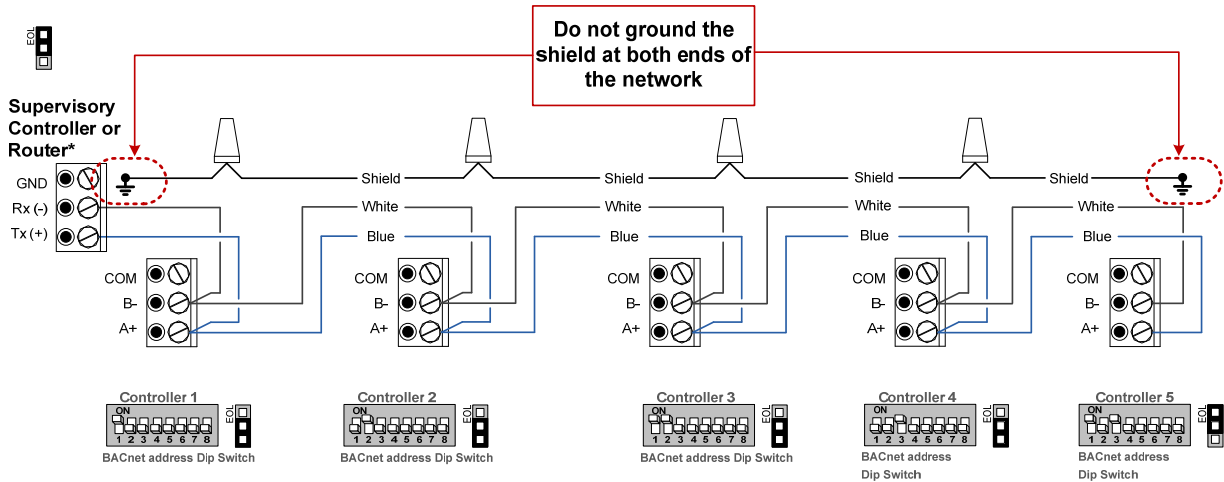

Illustration 5 - MS/TP Network Correct Shield Wiring



*\*Indicates non Neptronic devices or equipment.*

**Illustration 6 - MS/TP Network Incorrect Shield Wiring**

## End of Line (EOL) Termination

In order to avoid reflection issues, an End of Line (EOL) must be installed at both ends of the physical network wire. Set the EOL directly on the controller (with the on-board jumper or DIP switch) or manually wire a 120Ω resistor between A+ and B-. Communication is achieved by using an electrical pulse signal and when no EOLs are installed, the pulse signal reflects backwards and collides with other data pulses. The resistor absorbs the pulse energy and dissipates it as heat.

Neptronic devices use 120Ω resistor, but 3<sup>rd</sup> party devices may require a different resistor value. Consult the instruction manual of these devices.

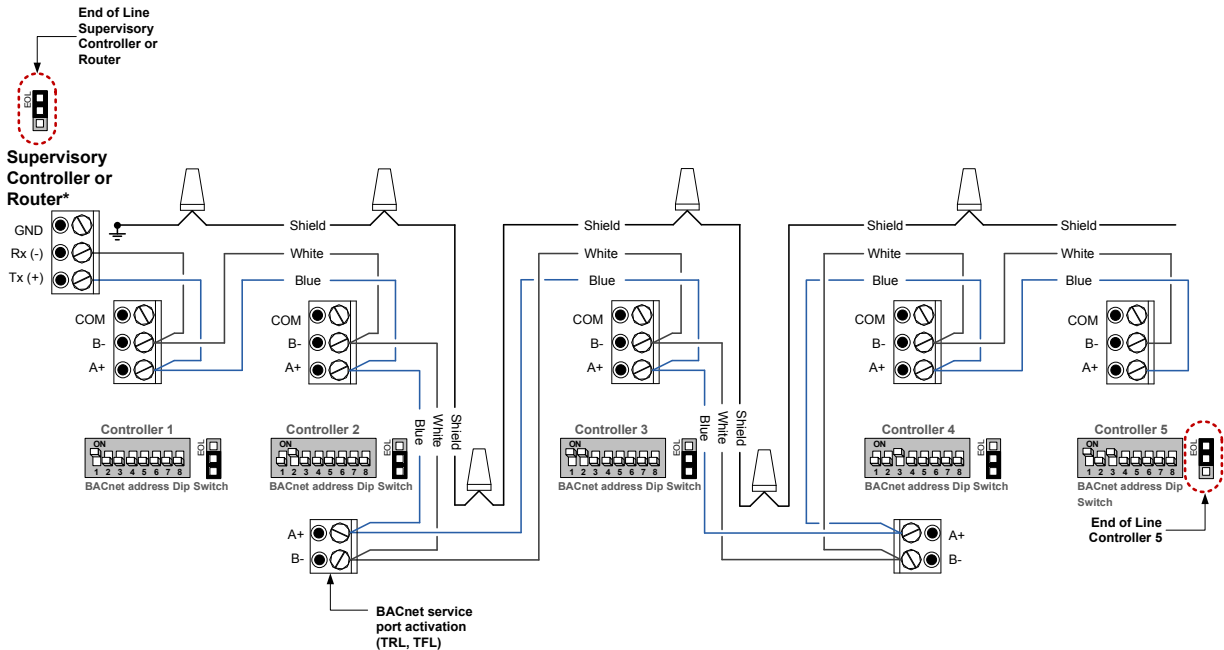

*\*Indicates non Neptronic devices or equipment.*

**Illustration 7 - MS/TP Network Correct EOL Setup**

Do not install EOL or termination resistor (120Ω) at any intermediate device on the network.

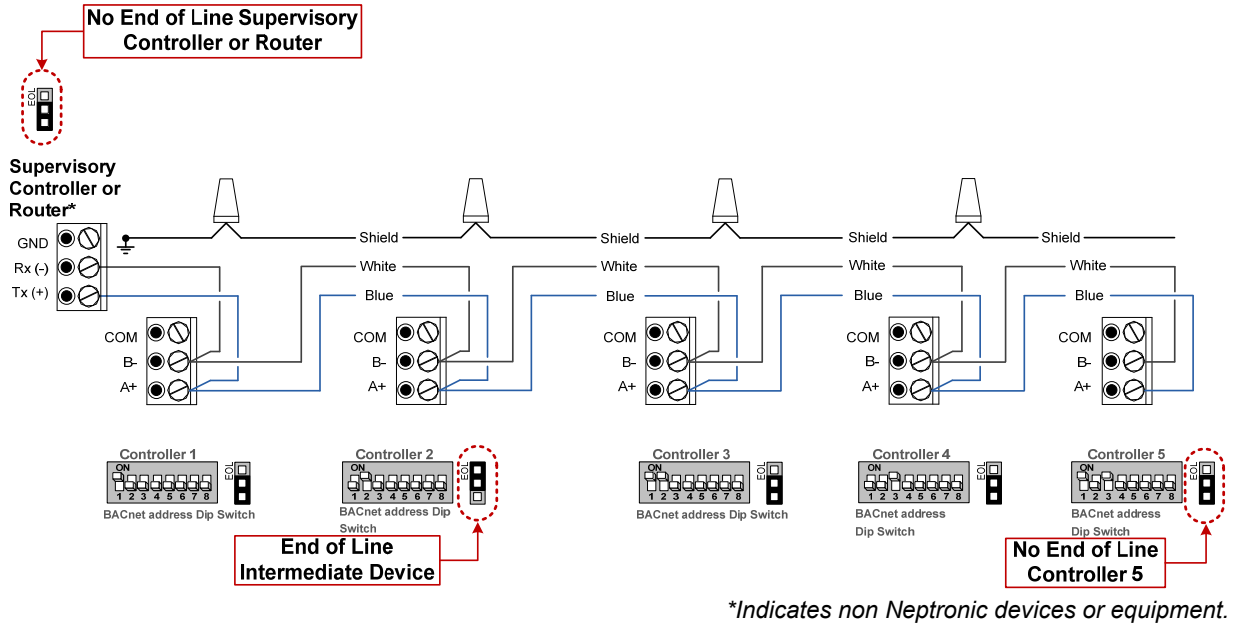

Illustration 8 - MS/TP Network Incorrect EOL Setup

If no EOL is available on the device, a 120Ω resistor can be wired between A+ and B-. For 3<sup>rd</sup> party devices, verify the EOL resistor value required.

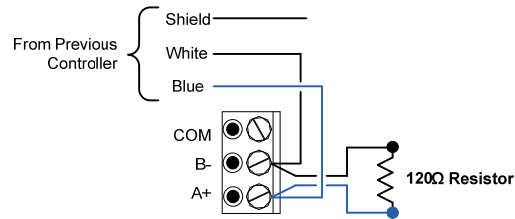

Illustration 9 - 120Ω Resistance EOL

## Repeater Usage

When a network contains more than 64 controllers and/or the cable length exceeds 4,000ft (1,200m) use one or more repeaters. Wire and configure the repeaters according to the manufacturer's specification. From each of those repeaters, a separate daisy chain will branch off. More than one repeater on a single MS/TP segment is not recommended.





Below are two examples of wiring repeaters;

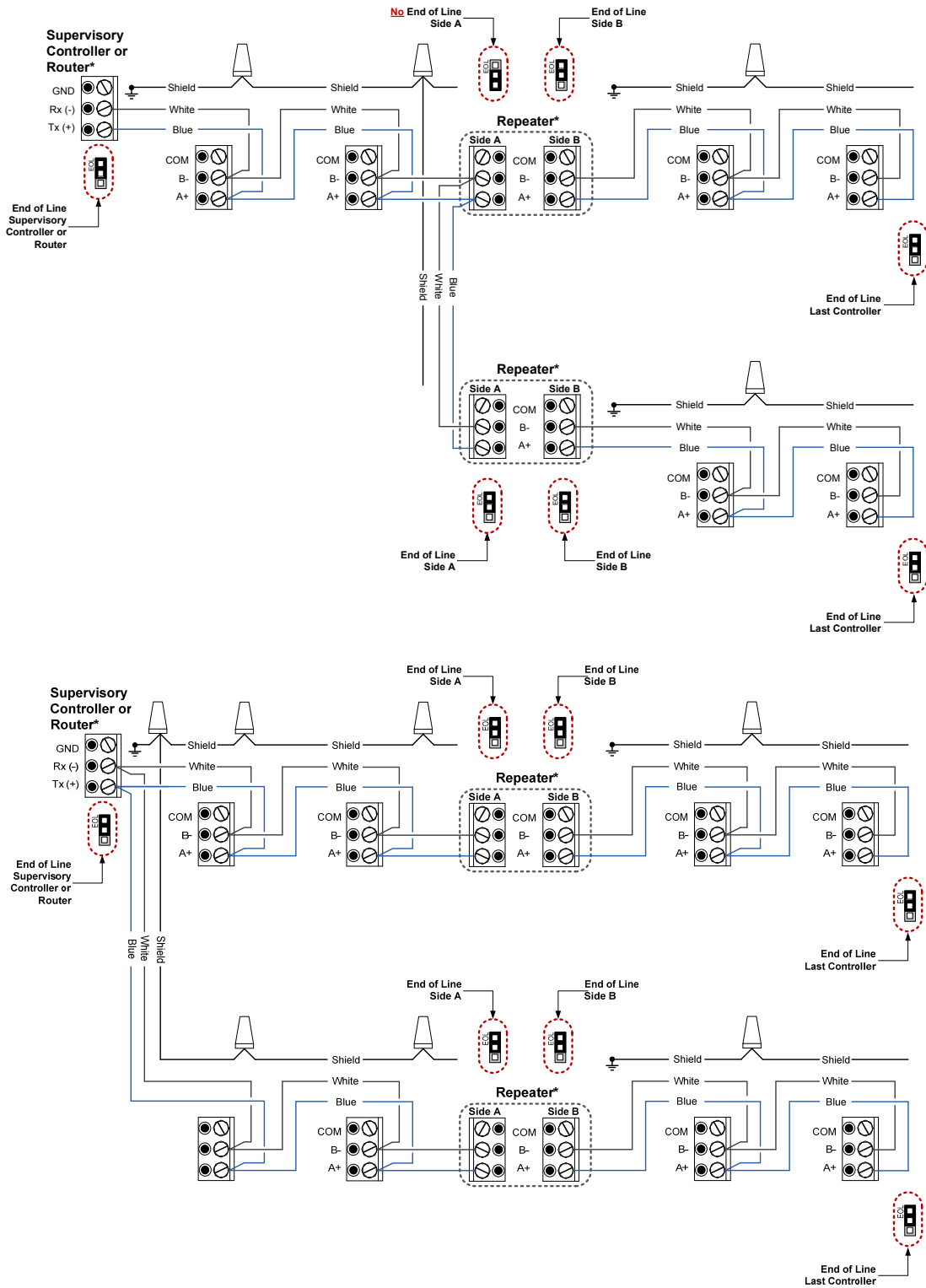

\*Indicates non Neptronic devices or equipment.

Illustration 10 - Using MS/TP Network Repeaters



## Addressing

### Baud Rate

Baud Rate is the rate at which data is communicated to the devices. You can configure the MS/TP networks to communicate at the following baud rates:

- 9.6 kbps
- 19.2 kbps
- 38.4 kbps
- 76.8 kbps
- Auto Detect

All the devices on the MS/TP segment must communicate at the same baud rate. Neptronic devices are capable of automatically configuring the baud rate upon detection of network speed. If the automatic baud rate detection option is OFF, manually configure the baud rate on the device.

### Addressing

The Device ID (Device Object Identifier) is used in a BACnet network as the unique identifier of a specific device. The Device ID for each device must be unique on the entire BACnet network.

### Device Instances

Device Instance can be in the range of 0 to 4194304. By using the default Neptronic scheme, the device instance is set to 0153xxx, where 153 is the Neptronic Vendor Identifier and xxx is the locally used MAC address of the device. The Device instance can be set via the device display or BACnet.

### MAC Addresses

The MAC address must be unique on a BACnet MT/TP segment. By default, the MAC address on our controllers is set to 0. A MAC address cannot be duplicated on a single MS/TP trunk. The MAC address can be set via on-board DIP switches, the device display or via BACnet.

### Master - Slave

0-127 addresses are for master devices and 128-254 addresses are reserved for slave devices. Only master devices can initiate requests and are part of the token passing. Slave devices cannot initiate requests for data, they only reply to messages from other master devices and are not part of the token passing. It is better to cluster all the devices at adjacent addresses to minimize unwanted Poll From Master (PFM). Refer to Optimize MAC Address & Max Master section to reduce PFM to a minimum.

### Max Master

In order to increase network efficiency, we recommend configuring the Max Master of the highest MAC device when there are less than 127 devices on the network. The Max Master prevents the Poll From Master (PFM) from exceeding the current value set. For example, 32 devices with MAC addresses ranging from 1 to 32 and a Max Master of 33 ensures that the PFM are not done for addresses higher than 33. If a new device is entered outside the set value of the MAX Master, the network will not see the device until the MAX Master has been changed to include the new device.

### Optimize MAC Address & Max Master

Some MAC address and Max Master combinations are more efficient than others. BACnet requires token-passing units to occasionally “poll” for other masters based on the MAC address and Max Master. A poor combination of MAC addresses and Max Master can lead to a slower network due to lost time polling for masters that are not present. Unless there are 126 other devices on the MS/TP segment, the default Max Master value of

127 is not the most efficient choice for the device. The Max Master default value of 127 was selected to ensure that any master, specifically a BACnet client can be found when a device is initially started.

As a general guideline, the most efficient setup for an MS/TP network is one in which the devices are consecutively numbered and having Max Master equal to the maximum MAC address in the system. If consecutive numbering is not possible then the next most efficient setup is one in which all devices have Max Master equal the maximum MAC address on the network.

## MAC Address Settings via DIP Switches

The Media Access Control address (MAC address) is defined using a binary logic of the DIP switches, where each switch represents a binary numerical value when the switch is set to ON. To set the MAC address, add the values of all the DIP switches in the ON position.

**i** When DIP switches are used to set the MAC address, it can no longer be changed via BACnet or device configuration display. To access the address via those two modes, the DIP switches must be all set at the OFF position.

**i** Note: MAC addresses on some devices are modifiable between 0-127 (DIP switches 1-7) and on others between 0-254 (DIP switches 1-8)

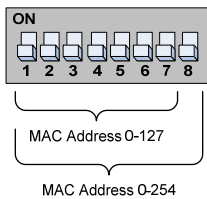

Device	Binary Value of DIP Switches								MAC Address
	DS.1 = 1	DS.2 = 2	DS.3 = 4	DS.4 = 8	DS.5 = 16	DS.6 = 32	DS.7 = 64	DS.8 = 128	
1	ON	OFF	ON	OFF	ON	OFF	OFF	OFF	21
2	OFF	ON	OFF	ON	OFF	ON	ON	OFF	106
3	ON	OFF	ON	OFF	ON	OFF	OFF	ON	149

Illustration 11 - MAC Address Configuration Example

- Device #1: DIP switches 1, 3, and 5 are set to ON, the MAC address will be 21 (sum of 1, 4, and 16).
- Device #2: DIP switches 2, 4, 6, and 7 are set to ON, the MAC address will be 106 (sum of 2, 8, 32, 64).
- Device #3: DIP switches 1, 3, 5, and 8 are set to ON, the MAC address will be 149 (sum of 1, 4, 16, 128).
- When combined with the default device instance (0153000 + MAC address);
  - Device #1 would have a device ID of 0153021.
  - Device #2 would have a device ID of 0153106.
  - Device #3 would have a device ID of 0153149.

## Troubleshooting Tips

1. Verify polarity on the communication cable. RS-485 achieves binary transmission by switching the voltage polarity between A+ and B-. If the Rx light is on when there is no communication, there is a good chance that the polarity has been reversed (signal ground to A+ & signal ground to B- voltage should be between 7V & 1.5V).
2. Ensure that all devices have a unique MAC address and Device Instance.
3. Ensure that all software device instances are unique on the whole network.
4. Validate that the baud rate is the same for all devices including repeaters.
5. Check if there are more than 2 EOL terminations present on the same segment. No intermediate device should have an EOL.
6. If there are 3<sup>rd</sup> party devices on the network, try to remove them. If they cause problems, put them on a different segment.
7. In order to help narrow down a communication issue, divide the network in half and verify if the devices come online. Repeat the operation until the network is functional.
8. Swap a working and a non-working device. If the problem moved with the device, then it indicates a configuration issue or problematic device. If the problem stays at the same location, then it indicates a wiring issue.



**neptronic®**

400 Lebeau blvd, Montreal, Qc, H4N 1R6, Canada

[www.neptronic.com](http://www.neptronic.com)

Toll free in North America: 1-800-361-2308

Tel.: (514) 333-1433

Fax: (514) 333-3163

Customer service fax: (514) 333-1091

Monday to Friday: 8:00am to 5:00pm (Eastern time)